

NOTES:

1. MATERIAL: AISI 304 STAINLESS STEEL

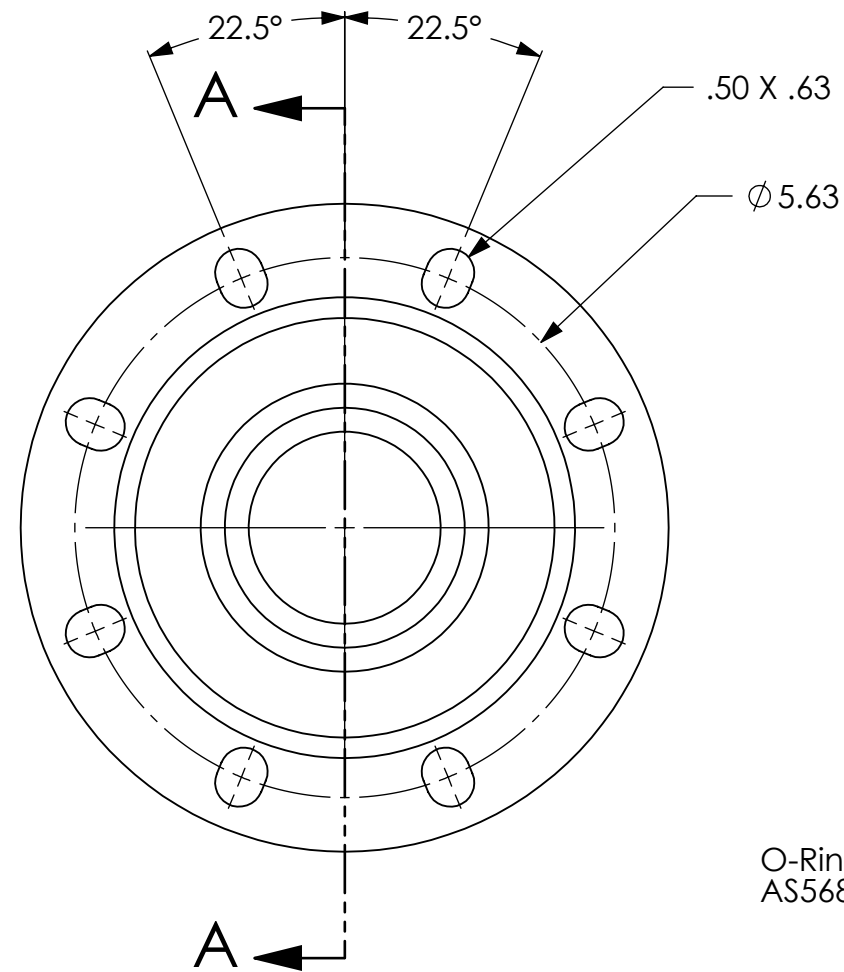
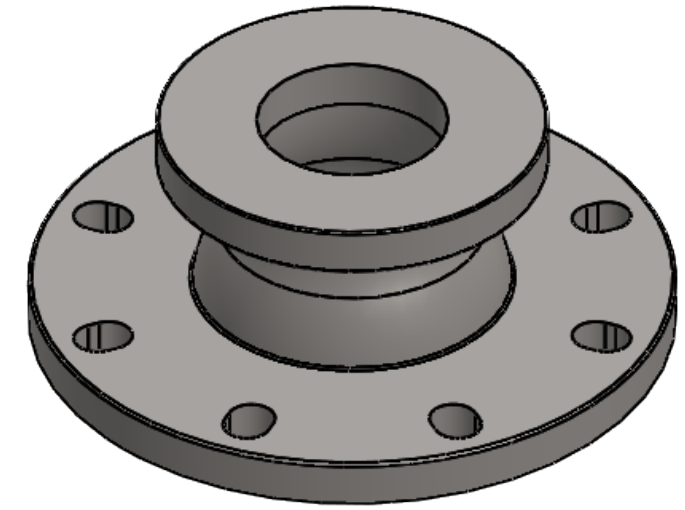

2433 Flange

Valve Flange 2.0

O-Ring Groove
AS568-246

2.50

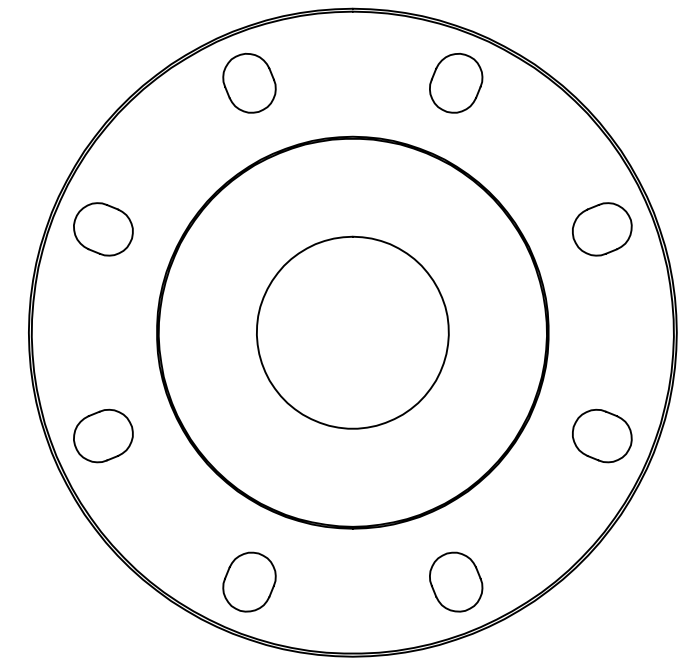

SECTION A-A

DRAWING NOTES UNLESS OTHERWISE SPECIFIED
 1. All dimensions are in inches.
 2. Do not scale drawing.
 3. Decimal Tolerance X.XX = +/- 0.01
 4. Decimal Tolerance X.XXX = +/- 0.005
 5. Fractional Tolerance X/X = +/- 1/16
 6. Angle Tolerance: 0.5 degrees



6405 SW 38th St, Bldg 200
 Ocala, FL 34474
 Phone: 800.327.7638
 www.fireprograms.com

TITLE
Cstg 2433 x Vlv S 2.0

APPROXIMATE WEIGHT (LBS)
5.90

THE INFORMATION CONTAINED IN THIS DRAWING IS THE SOLE PROPERTY OF FIRE PROGRAMS, LLC. ANY REPRODUCTION IN PART OR AS A WHOLE WITHOUT THE WRITTEN PERMISSION OF FIRE PROGRAMS, LLC IS PROHIBITED.

DRAWING NUMBER
500521

REV A	SHEET SCALE 1:2
DATE 11/10/2025	SHEET 1 OF 2

REVISIONS		
REV.	DATE	DESCRIPTION
A	11/10/2025	Initial Release

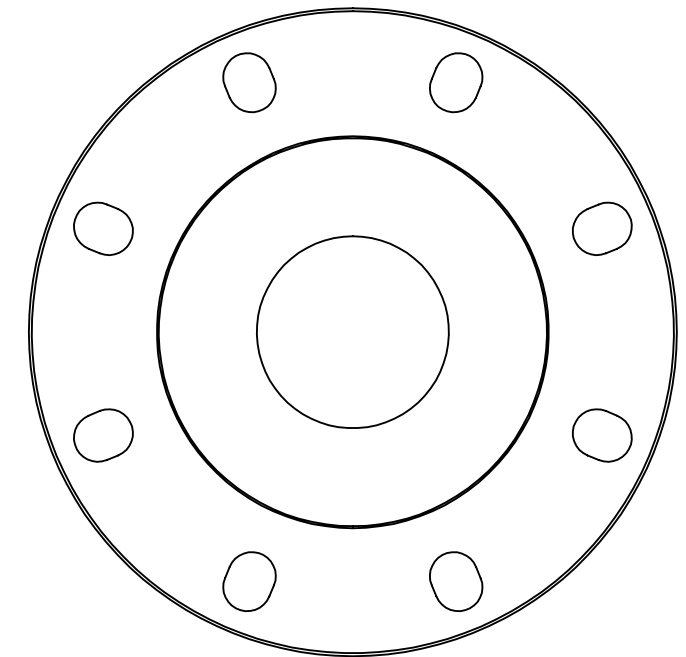
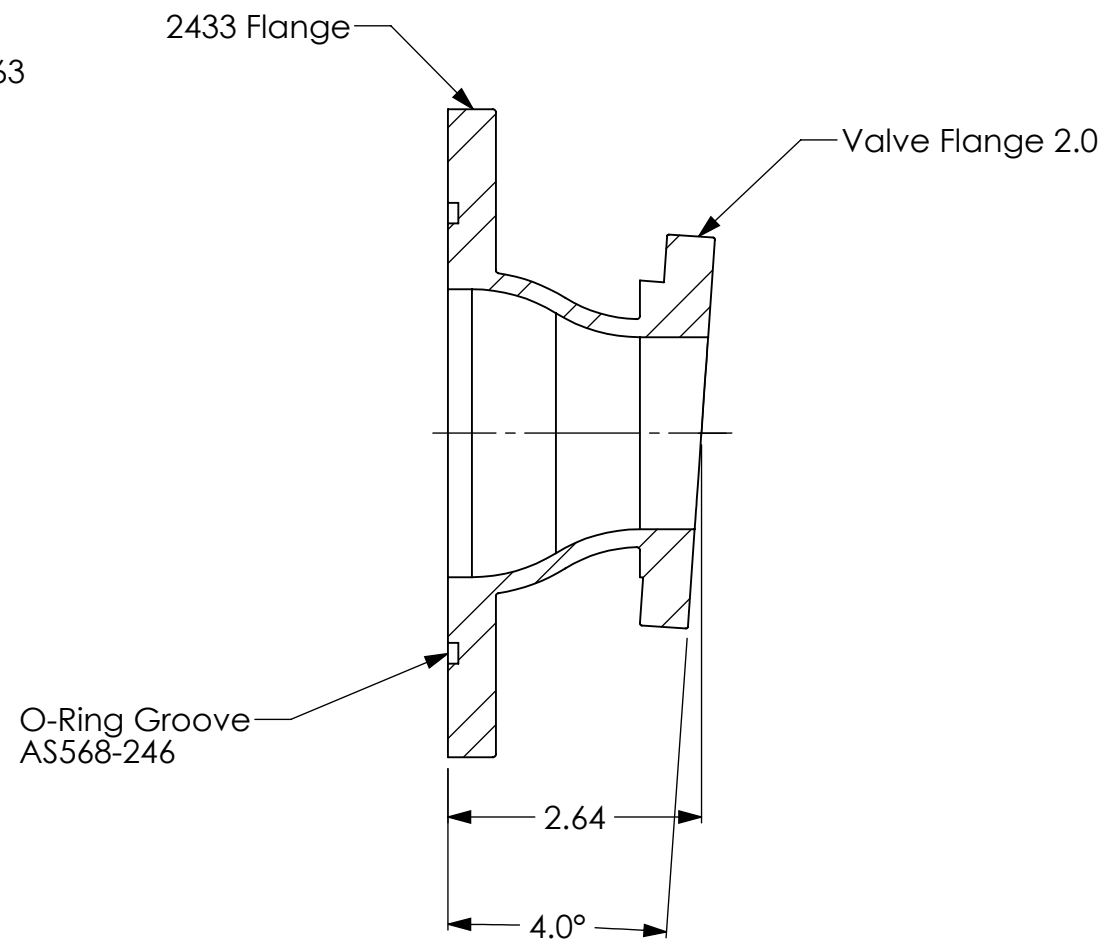
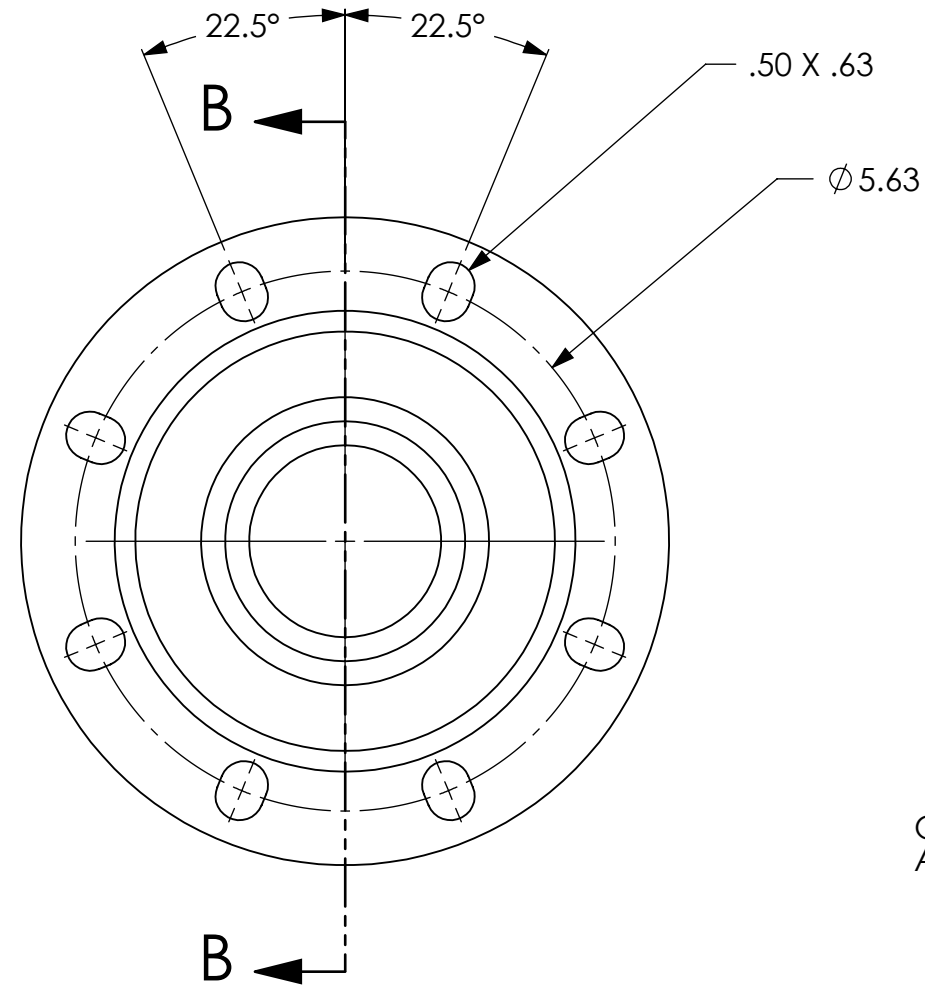
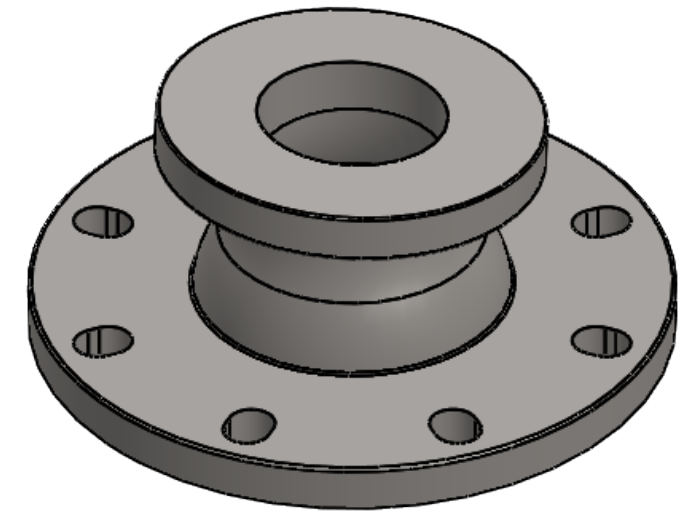

SECTION B-B

<p>DRAWING NOTES UNLESS OTHERWISE SPECIFIED</p> <ol style="list-style-type: none"> All dimensions are in inches. Do not scale drawing. Decimal Tolerance X.XX = +/- 0.01 Decimal Tolerance X.XXX = +/- 0.005 Fractional Tolerance X/X = +/- 1/16 Angle Tolerance: 0.5 degrees
<p>APPROXIMATE WEIGHT (LBS)</p> <p>5.90</p>
<p>THE INFORMATION CONTAINED IN THIS DRAWING IS THE SOLE PROPERTY OF FIRE PROGRAMS, LLC. ANY REPRODUCTION IN PART OR AS A WHOLE WITHOUT THE WRITTEN PERMISSION OF FIRE PROGRAMS, LLC IS PROHIBITED.</p>

<p>FirePrograms SOFTWARE</p>	<p>6405 SW 38th St, Bldg 200 Ocala, FL 34474 Phone: 800.327.7638 www.fireprograms.com</p>	
	<p>TITLE Cstg 2433 x Vlv S 2.0 4 Deg</p>	
<p>DRAWING NUMBER 500521-4</p>	<p>REV A</p>	<p>SHEET SCALE 1:2</p>
	<p>DATE 11/10/2025</p>	<p>SHEET 2 OF 2</p>