

NOTES:

1. MATERIAL: AISI 304 STAINLESS STEEL.

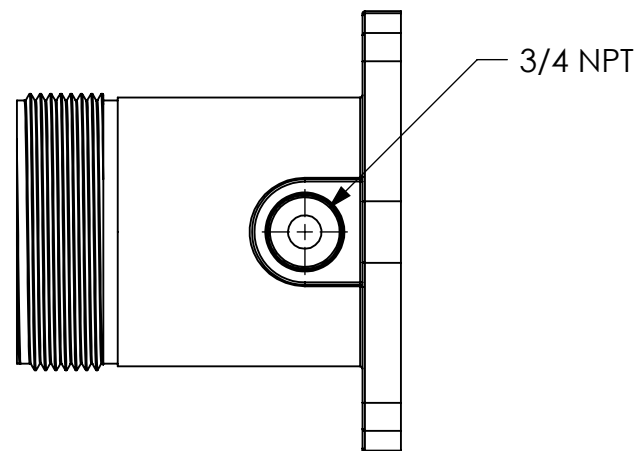
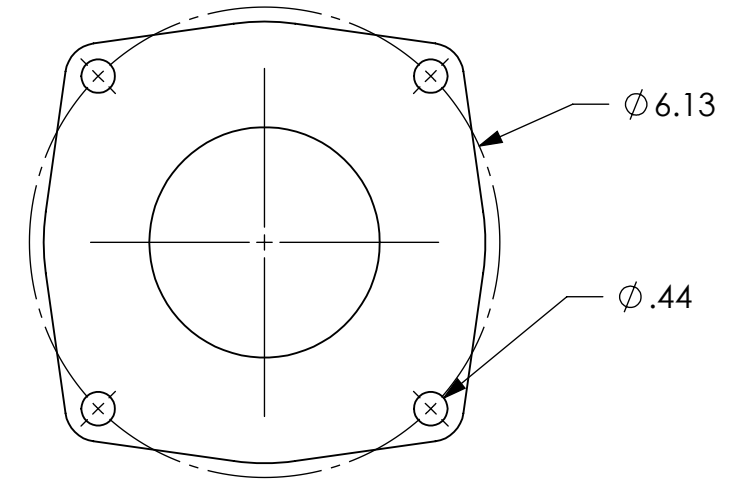
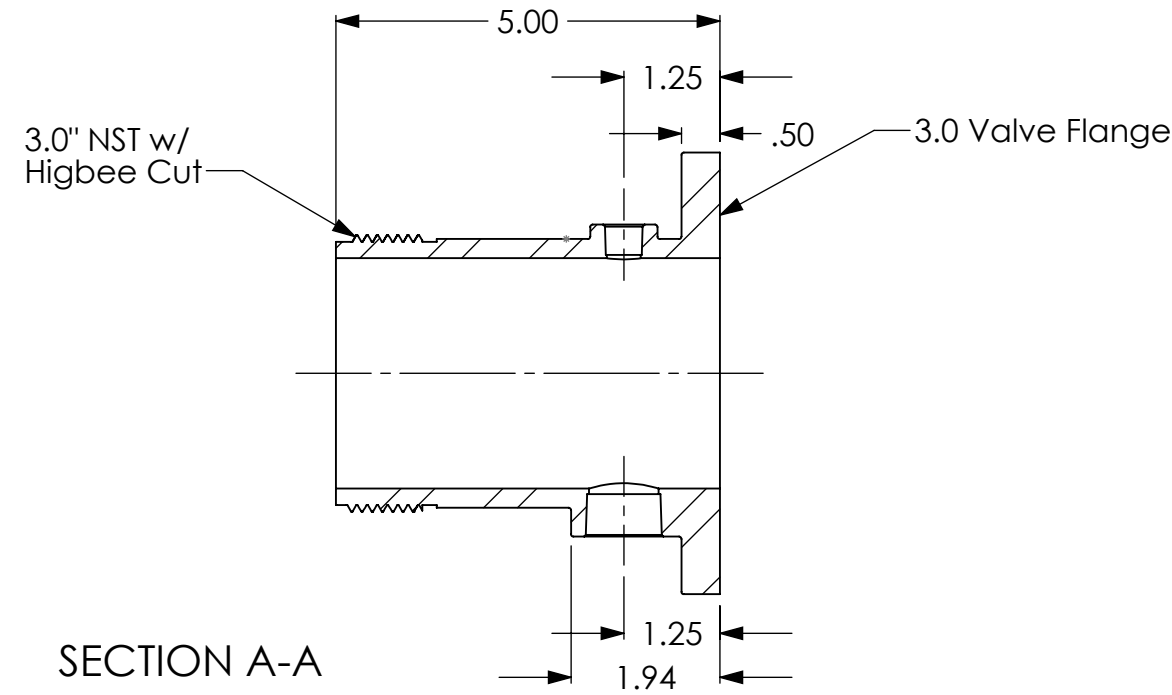
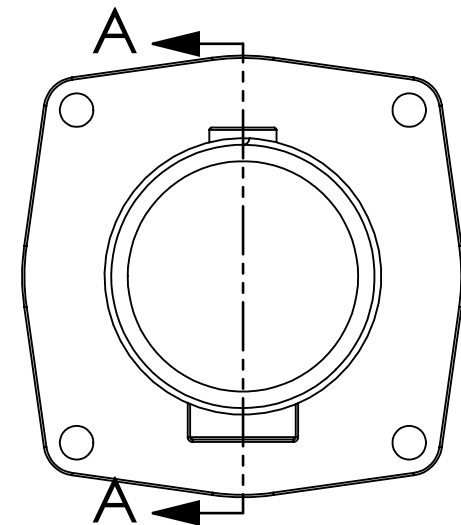
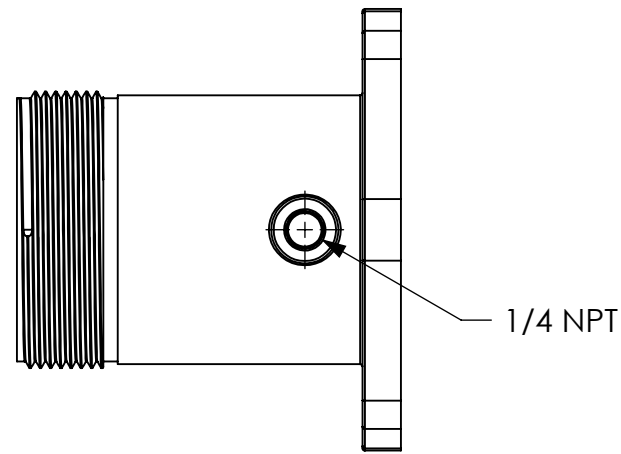
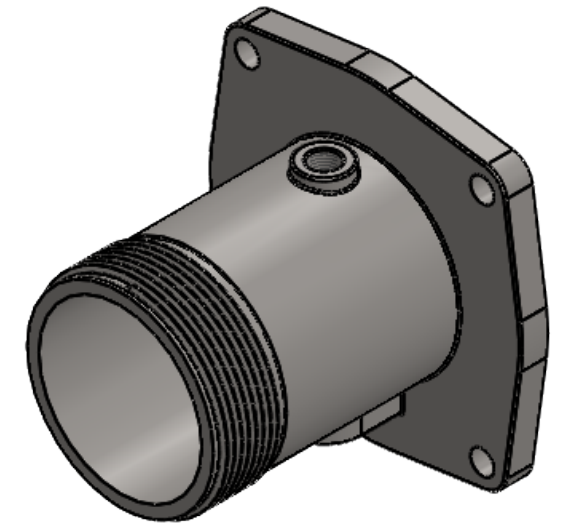

DRAWING NOTES UNLESS OTHERWISE SPECIFIED 1. All dimensions are in inches. 2. Do not scale drawing. 3. Decimal Tolerance X.XX = +/- 0.01 4. Decimal Tolerance X.XXX = +/- 0.005 5. Fractional Tolerance X/X = +/- 1/16 6. Angle Tolerance: +/- 1.0 degree	FirePrograms TITLE Cstg 3.0 Vlv x 3.0 NST w/ Drain		6405 SW 38th St, Bldg 200 Ocala, FL 34474 Phone: 800.327.7638 www.fireprograms.com		
	APPROXIMATE WEIGHT (LBS) 6.545		DRAWING NUMBER 500443		
THE INFORMATION CONTAINED IN THIS DRAWING IS THE SOLE PROPERTY OF FIRE PROGRAMS, LLC. ANY REPRODUCTION IN PART OR AS A WHOLE WITHOUT THE WRITTEN PERMISSION OF FIRE PROGRAMS, LLC IS PROHIBITED.		REV A	SHEET SCALE 1:2.5	DATE 10/31/2024	SHEET 1 OF 1

REVISIONS			
REV.	DATE	DESCRIPTION	
A	10/31/2024	Initial Release	