

NOTES:

1. MATERIAL: AISI 304 STAINLESS STEEL.

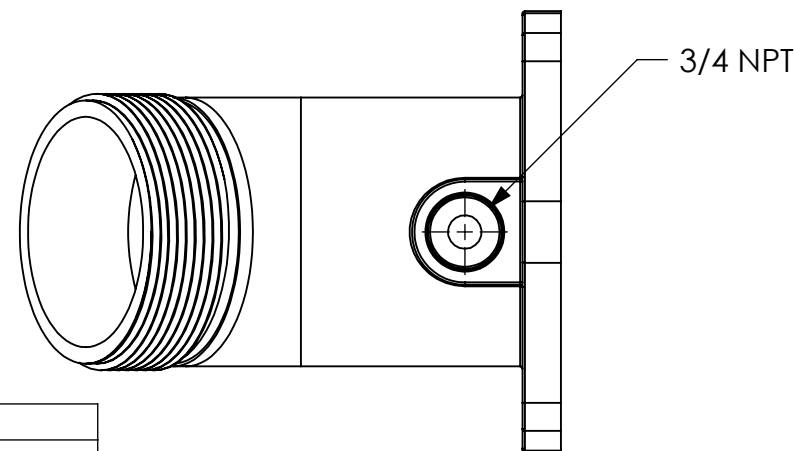
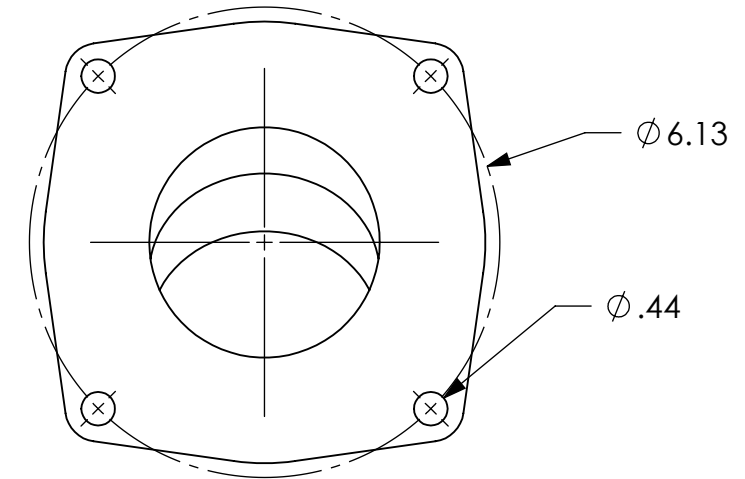
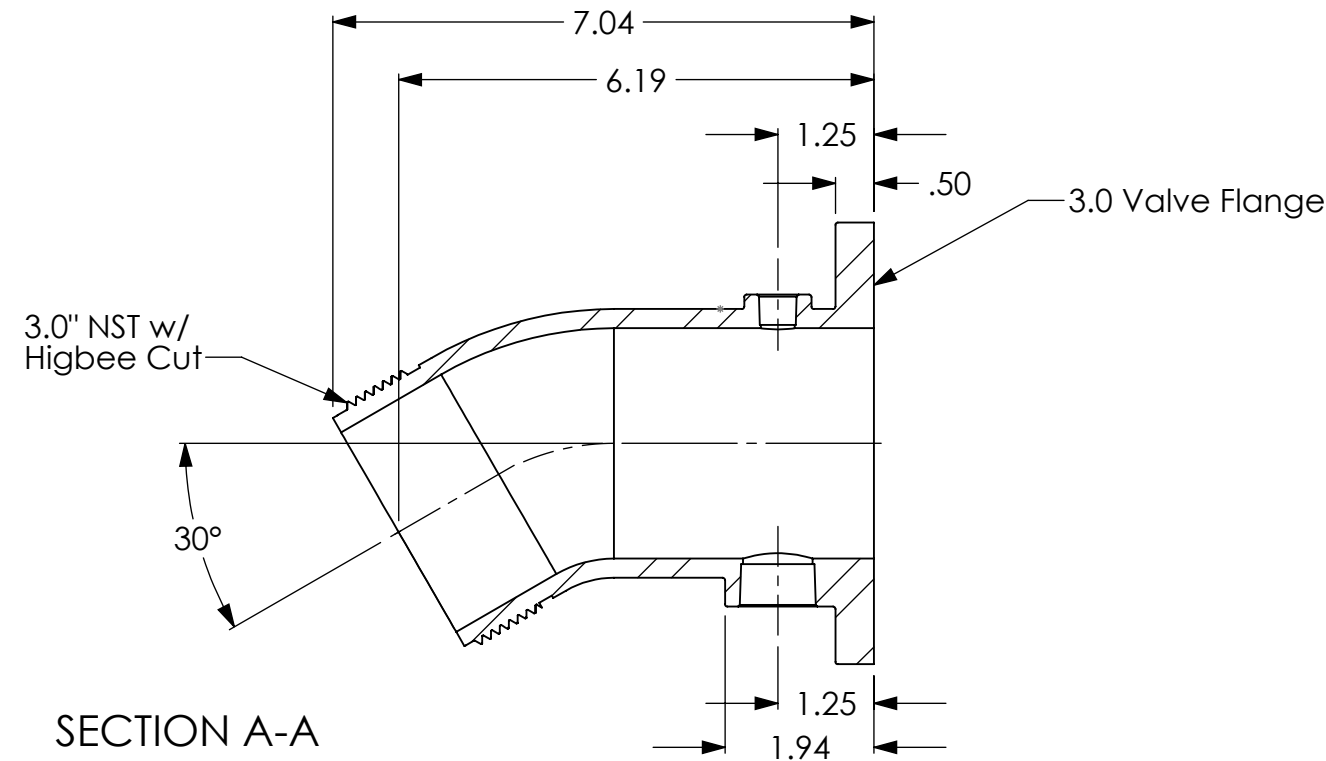
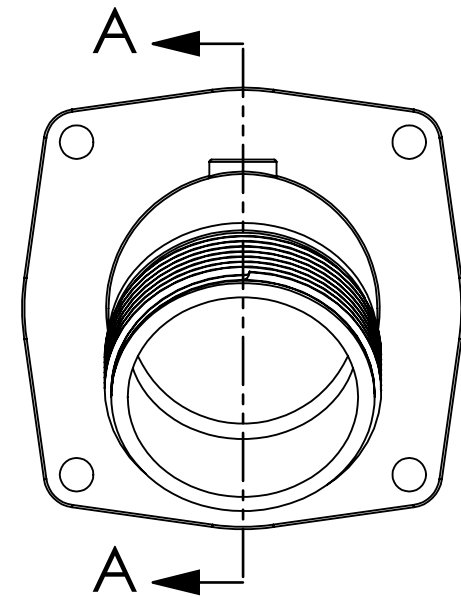
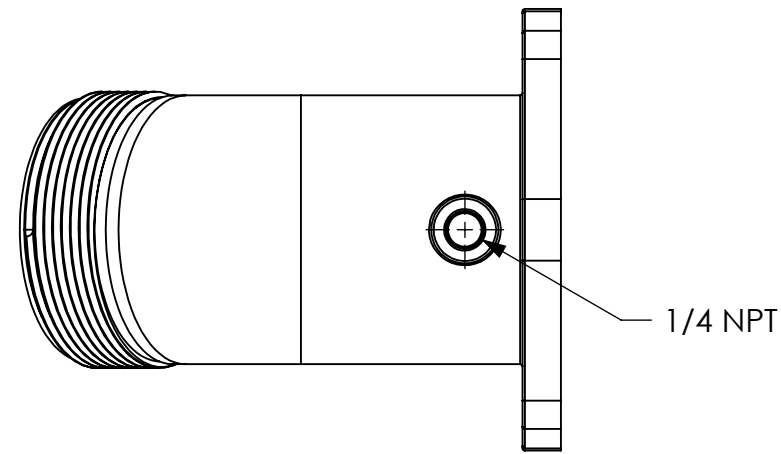
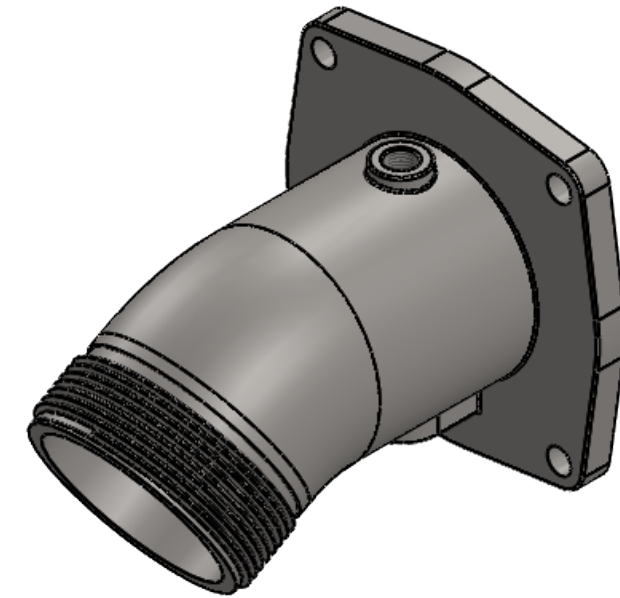

DRAWING NOTES UNLESS OTHERWISE SPECIFIED 1. All dimensions are in inches. 2. Do not scale drawing. 3. Decimal Tolerance X.XX = +/- 0.01 4. Decimal Tolerance X.XXX = +/- 0.005 5. Fractional Tolerance X/X = +/- 1/16 6. Angle Tolerance: +/- 1.0 degree	FirePrograms 6405 SW 38th St, Bldg 200 Ocala, FL 34474 Phone: 800.327.7638 www.fireprograms.com	
	TITLE Cstg 3.0 Vlv x 3.0 NST 30 Deg w/ Drain	
APPROXIMATE WEIGHT (LBS) 7.622	DRAWING NUMBER 500442	REV A SHEET SCALE 1:2.5
THE INFORMATION CONTAINED IN THIS DRAWING IS THE SOLE PROPERTY OF FIRE PROGRAMS, LLC. ANY REPRODUCTION IN PART OR AS A WHOLE WITHOUT THE WRITTEN PERMISSION OF FIRE PROGRAMS, LLC IS PROHIBITED.	DATE 10/31/2024	SHEET 1 OF 1

REVISIONS		
REV.	DATE	DESCRIPTION
A	10/31/2024	Initial Release