

NOTES:

1. MATERIAL: AISI 304 STAINLESS STEEL .
2. POLISH IN INDICATED AREA.
3. LEAK TEST TO 500 PSI FOR 1 MINUTE.

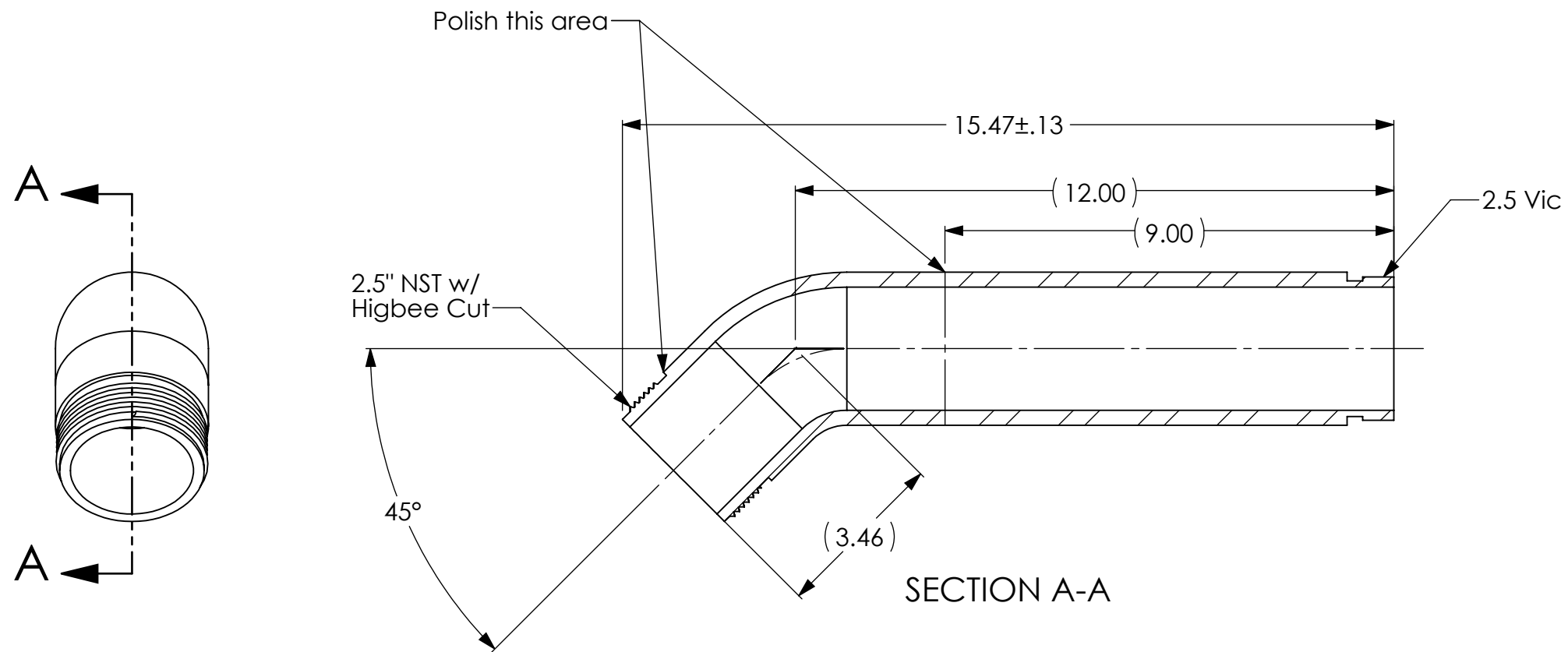
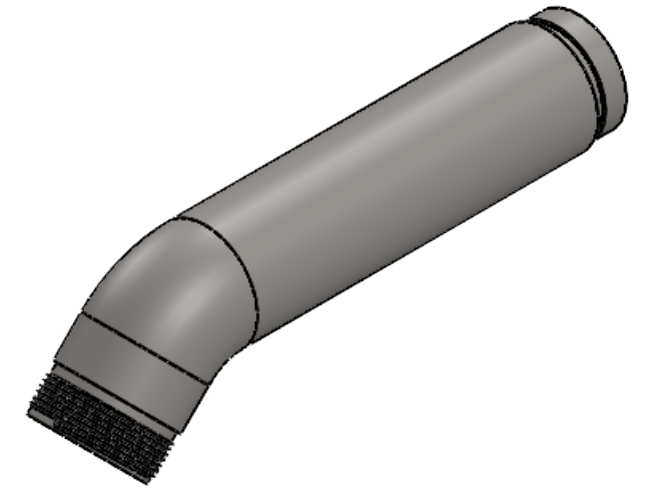

Part Number	Surface Finish
500329-U	As cast finish.
500329	Polish exterior surfaces as indicated.

DRAWING NOTES UNLESS OTHERWISE SPECIFIED  
 1. All dimensions are in inches.  
 2. Do not scale drawing.  
 3. Decimal Tolerance X.XX = +/- 0.01  
 4. Decimal Tolerance X.XXX = +/- 0.005  
 5. Fractional Tolerance X/X = +/- 1/16  
 6. Angle Tolerance: 0.5 degrees

**FirePrograms**

6405 SW 38th St, Bldg 200  
 Ocala, FL 34474  
 Phone: 800.327.7638  
 www.fireprograms.com

TITLE  
**Cstg 2.5 NST 45 Deg x 2.5 V**

APPROXIMATE WEIGHT (LBS)  
 11.050

THE INFORMATION CONTAINED IN THIS DRAWING IS THE SOLE PROPERTY OF FIRE PROGRAMS, LLC. ANY REPRODUCTION IN PART OR AS A WHOLE WITHOUT THE WRITTEN PERMISSION OF FIRE PROGRAMS, LLC IS PROHIBITED.

DRAWING NUMBER  
**500329**

REV B	SHEET SCALE 1:3
DATE 12/7/2023	SHEET 1 OF 1

REVISIONS		
REV.	DATE	DESCRIPTION
A	6/20/2023	Initial Release
B	12/7/2023	Increased wall thickness to 0.300