

NOTES:

1. MATERIAL: AISI 304 STAINLESS STEEL.

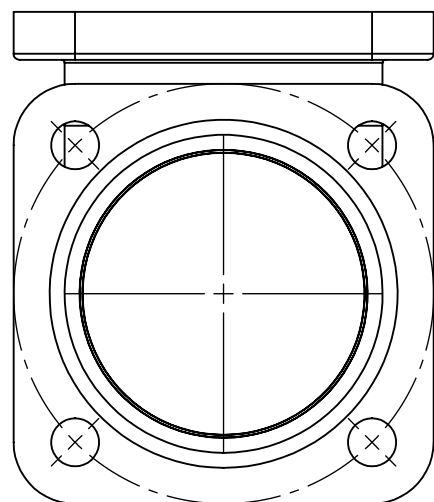
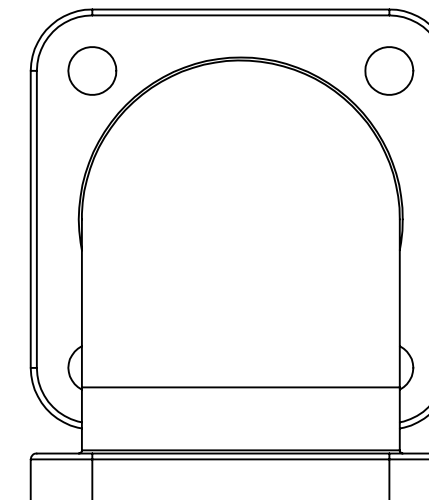
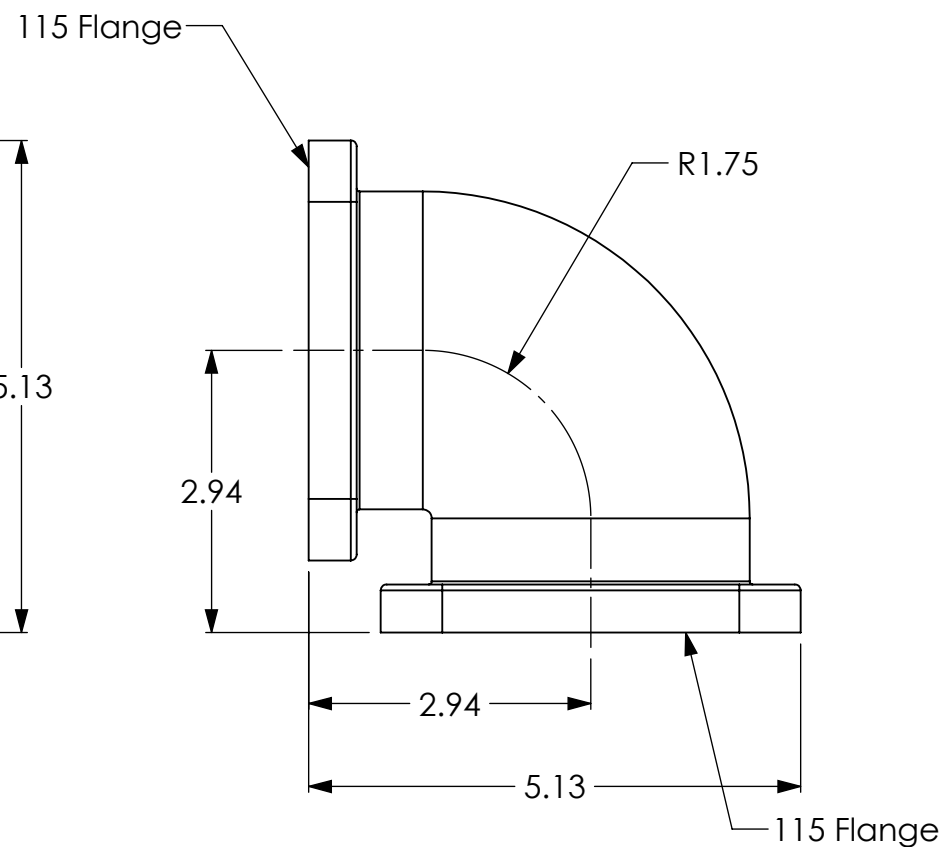
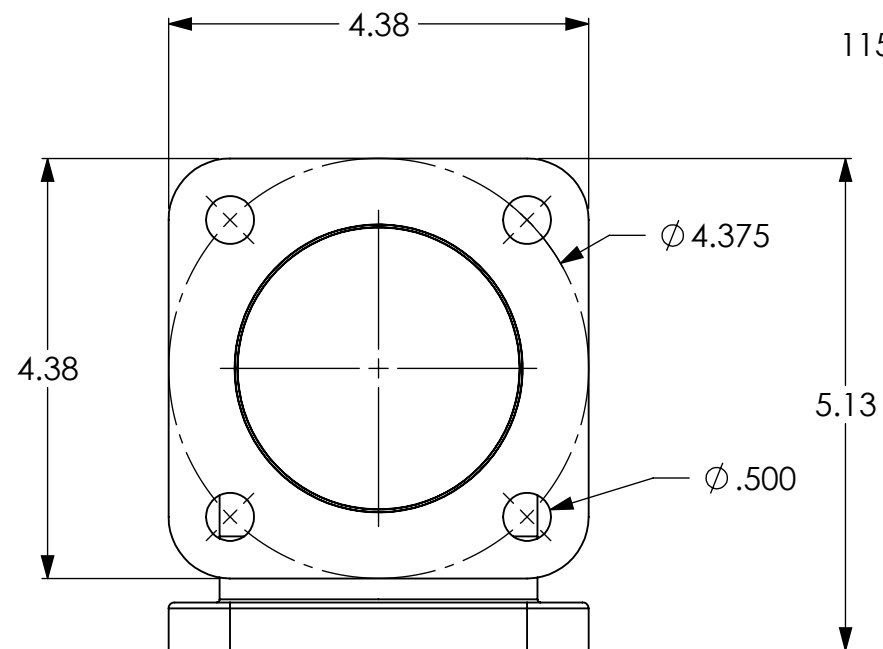
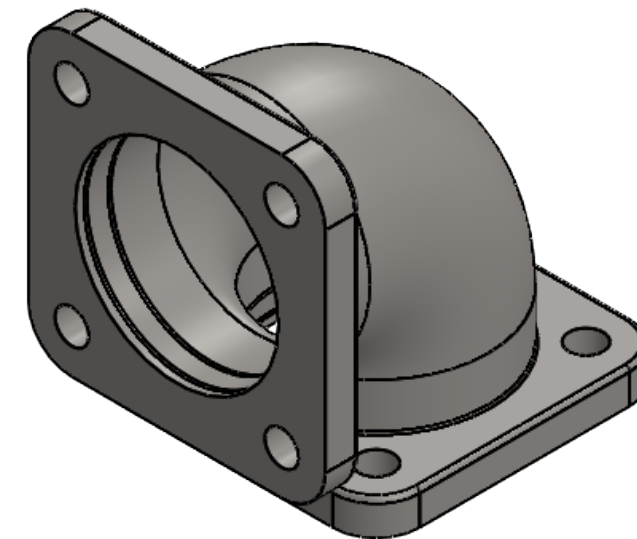

DRAWING NOTES UNLESS OTHERWISE SPECIFIED
 1. All dimensions are in inches.
 2. Do not scale drawing.
 3. Decimal Tolerance X.XX = +/- 0.01
 4. Decimal Tolerance X.XXX = +/- 0.005
 5. Fractional Tolerance X/X = +/- 1/16
 6. Angle Tolerance: 0.5 degrees

APPROXIMATE WEIGHT (LBS)
 5.33

THE INFORMATION CONTAINED IN THIS DRAWING IS THE SOLE PROPERTY OF FIRE PROGRAMS, LLC. ANY REPRODUCTION IN PART OR AS A WHOLE WITHOUT THE WRITTEN PERMISSION OF FIRE PROGRAMS, LLC IS PROHIBITED.

FirePrograms

6405 SW 38th St, Bldg 200
 Ocala, FL 34474
 Phone: 800.327.7638
 www.fireprograms.com

TITLE
**Cstg Elbow 90 Deg
 115 x 115**

DRAWING NUMBER
500282

| | |
|-------------------|--------------------|
| REV A | SHEET SCALE 1:2 |
| DATE 5/12/2021 | SHEET 1 OF 1 |

REVISIONS

| REV. | DATE | DESCRIPTION |
|------|-----------|-----------------|
| A | 5/12/2021 | Initial Release |