

NOTES:

1. MATERIAL: AISI 304 STAINLESS STEEL.

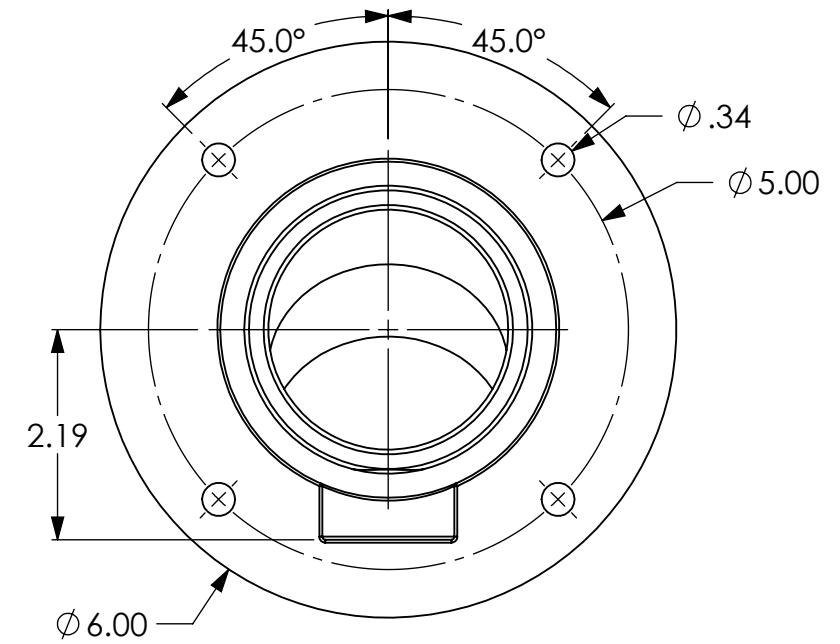

SECTION A-A

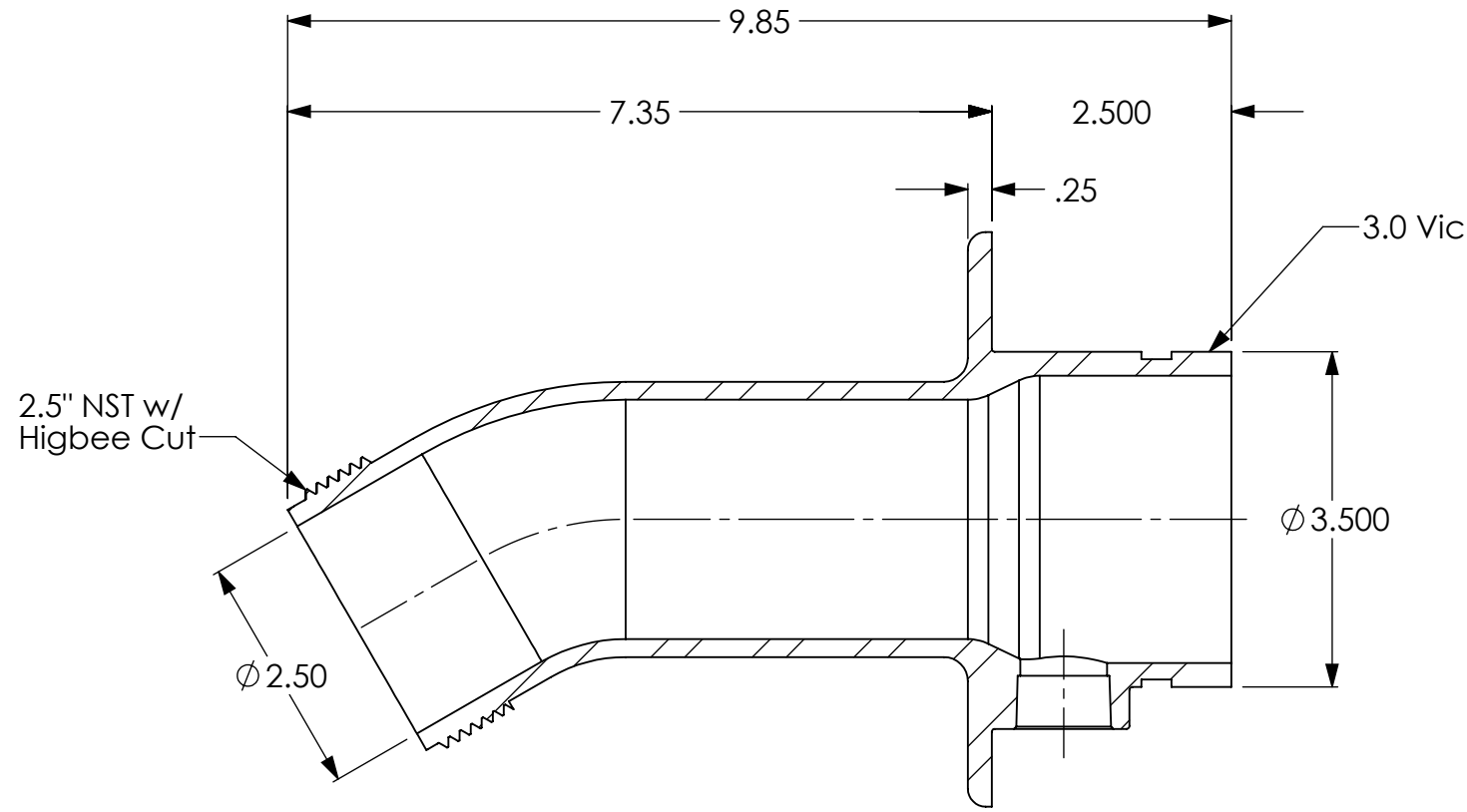
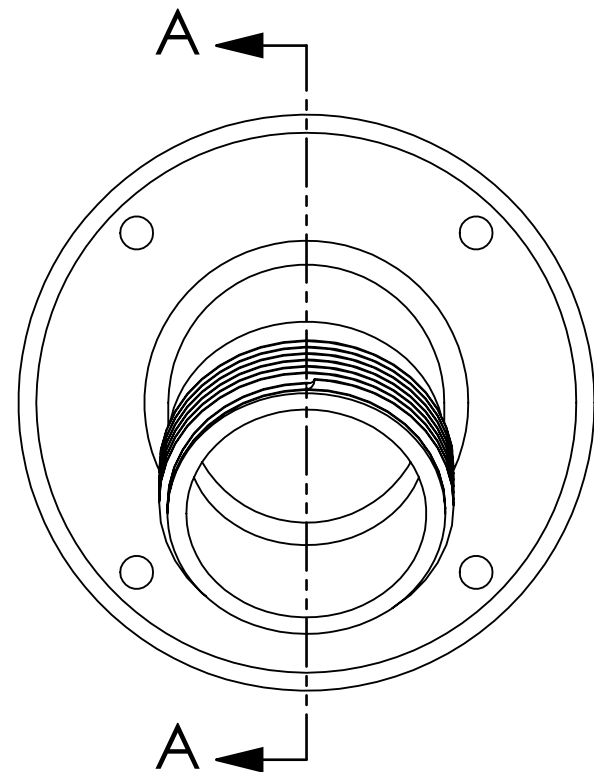
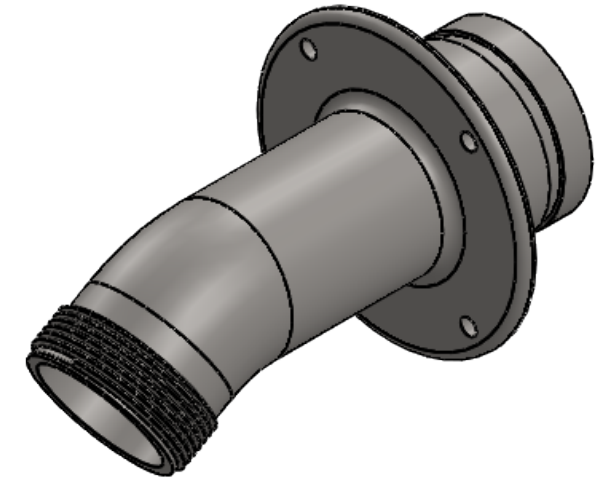
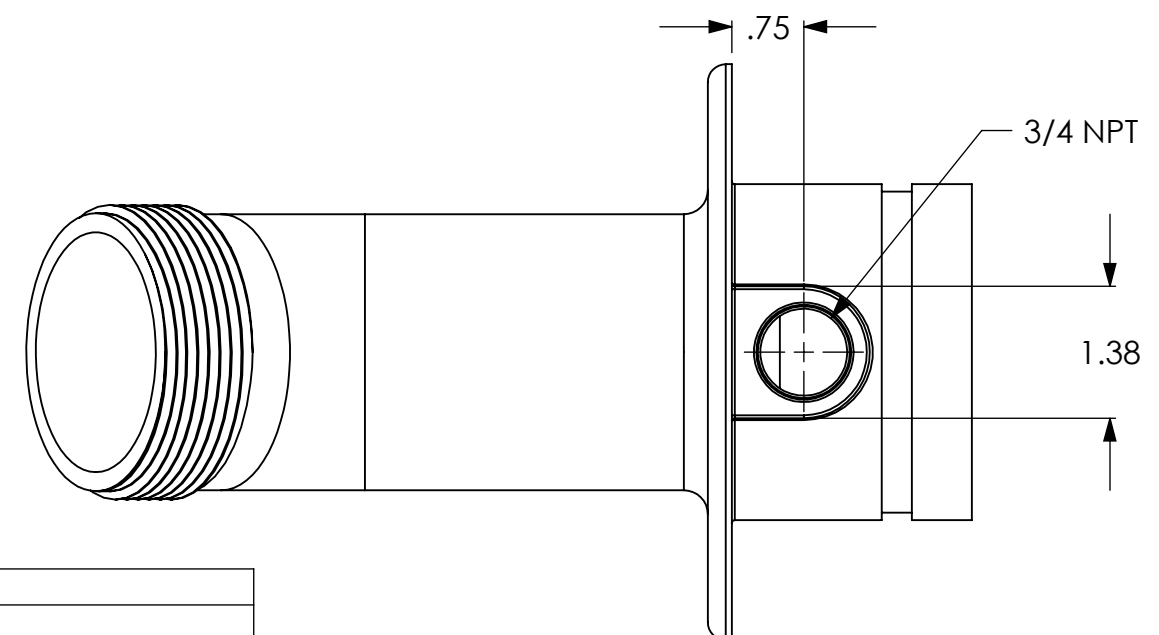

DRAWING NOTES UNLESS OTHERWISE SPECIFIED  
 1. All dimensions are in inches.  
 2. Do not scale drawing.  
 3. Decimal Tolerance X.XX = +/- 0.01  
 4. Decimal Tolerance X.XXX = +/- 0.005  
 5. Fractional Tolerance X/X = +/- 1/16  
 6. Angle Tolerance: 0.5 degrees

APPROXIMATE WEIGHT (LBS)  
 6.775

THE INFORMATION CONTAINED IN THIS DRAWING IS THE SOLE PROPERTY OF FIRE PROGRAMS, LLC. ANY REPRODUCTION IN PART OR AS A WHOLE WITHOUT THE WRITTEN PERMISSION OF FIRE PROGRAMS, LLC IS PROHIBITED.

		6405 SW 38th St, Bldg 200 Ocala, FL 34474 Phone: 800.327.7638 www.fireprograms.com	
		TITLE <b>Cstg 2.5 NST 30 Deg Long x 3.0 V w/ Mtg Flange</b>	
DRAWING NUMBER <b>500268</b>		REV A	SHEET SCALE 1:2
		DATE 2/23/2021	SHEET 1 OF 1

REVISIONS			
REV.	DATE	DESCRIPTION	
A	2/23/2021	Initial Release	