

NOTES:

1. MATERIAL: AISI 304 STAINLESS STEEL.

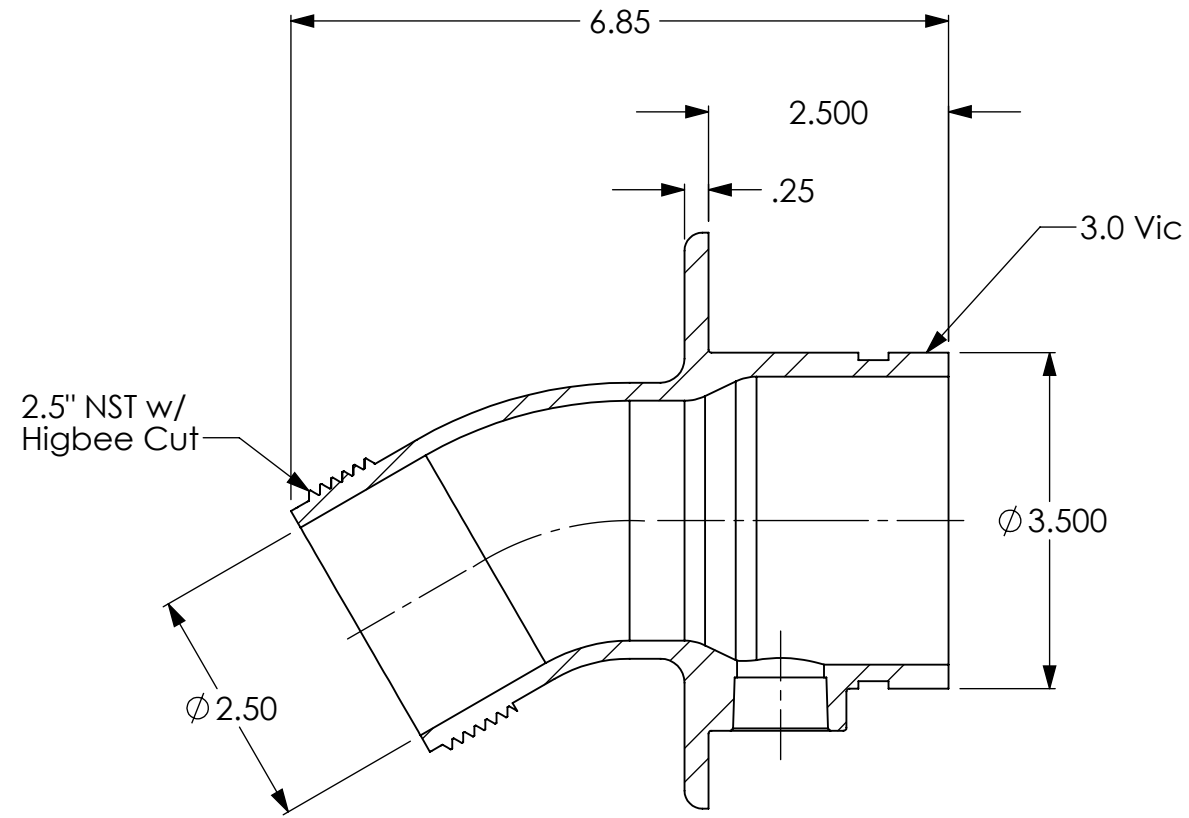

SECTION A-A

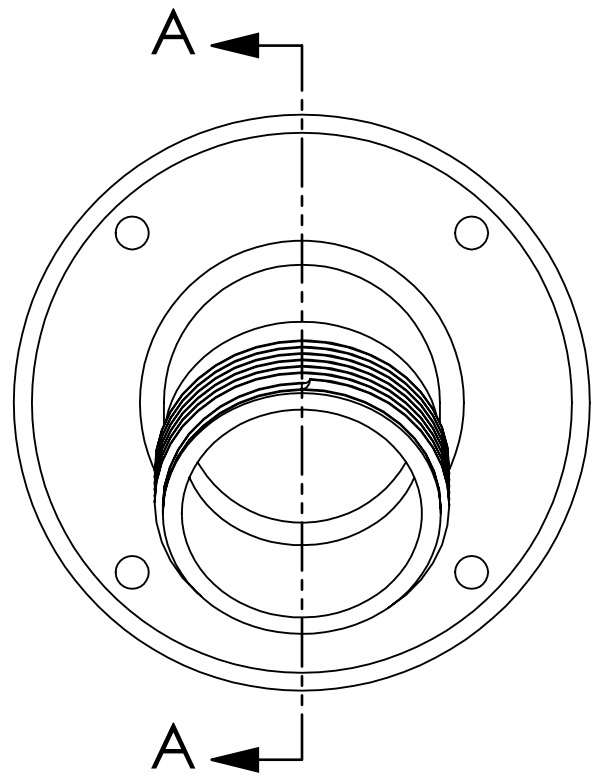
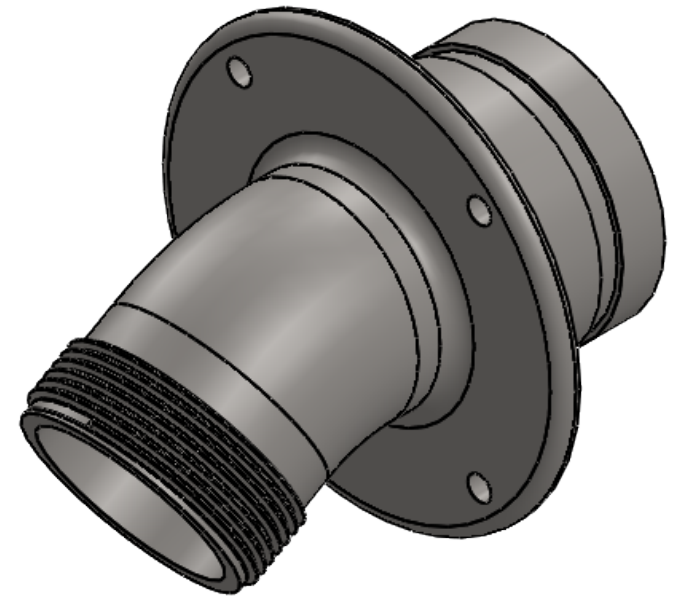
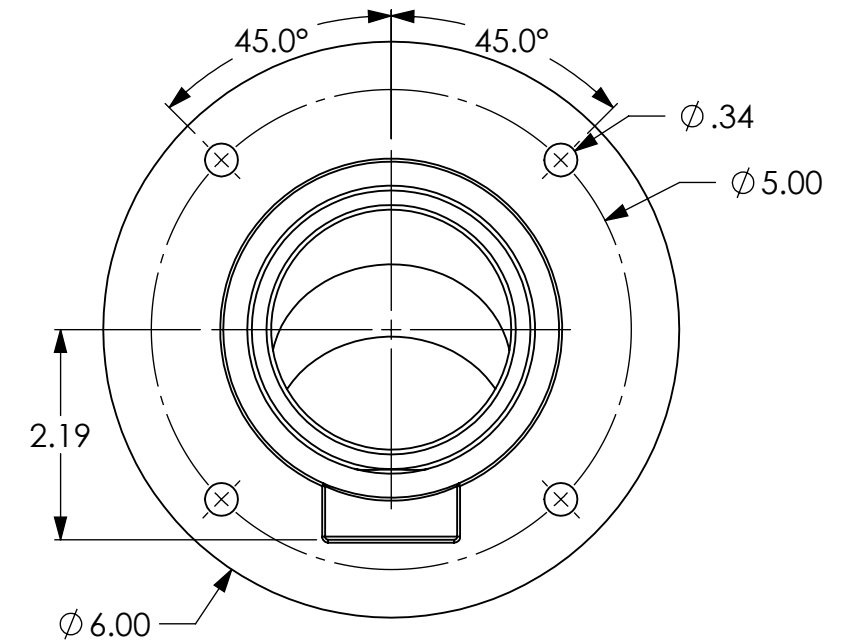
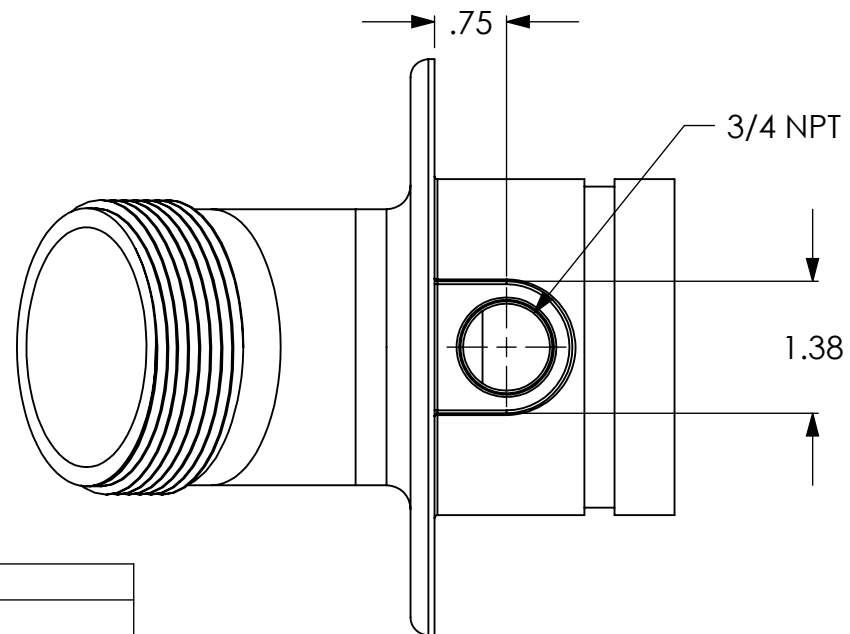

DRAWING NOTES UNLESS OTHERWISE SPECIFIED  
 1. All dimensions are in inches.  
 2. Do not scale drawing.  
 3. Decimal Tolerance X.XX = +/- 0.01  
 4. Decimal Tolerance X.XXX = +/- 0.005  
 5. Fractional Tolerance X/X = +/- 1/16  
 6. Angle Tolerance: 0.5 degrees

**FirePrograms**  
 6405 SW 38th St, Bldg 200  
 Ocala, FL 34474  
 Phone: 800.327.7638  
 www.fireprograms.com

TITLE  
**Cstg 2.5 NST 30 Deg x 3.0 V  
 w/ Mtg Flange**

APPROXIMATE WEIGHT (LBS)  
 5.403

THE INFORMATION CONTAINED IN THIS DRAWING IS THE SOLE PROPERTY OF FIRE PROGRAMS, LLC. ANY REPRODUCTION IN PART OR AS A WHOLE WITHOUT THE WRITTEN PERMISSION OF FIRE PROGRAMS, LLC IS PROHIBITED.

DRAWING NUMBER  
**500257**

REV A	SHEET SCALE 1:2
DATE 9/17/2020	SHEET 1 OF 1

REVISIONS		
REV.	DATE	DESCRIPTION
A	9/17/2020	Initial Release