

NOTES:

- MATERIAL: AISI 304 STAINLESS STEEL (PASSIVATED).

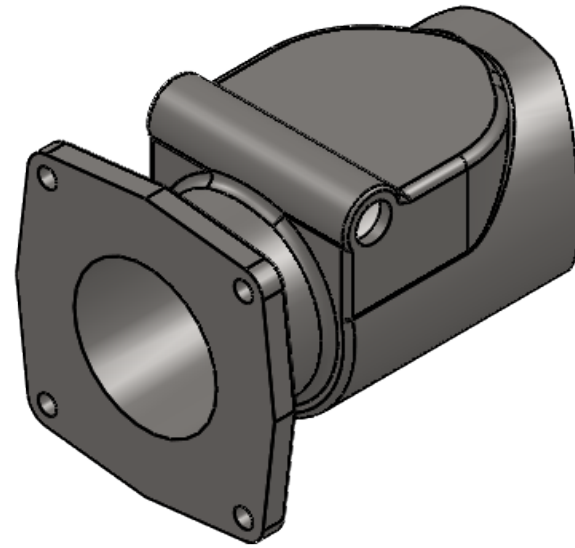

500020

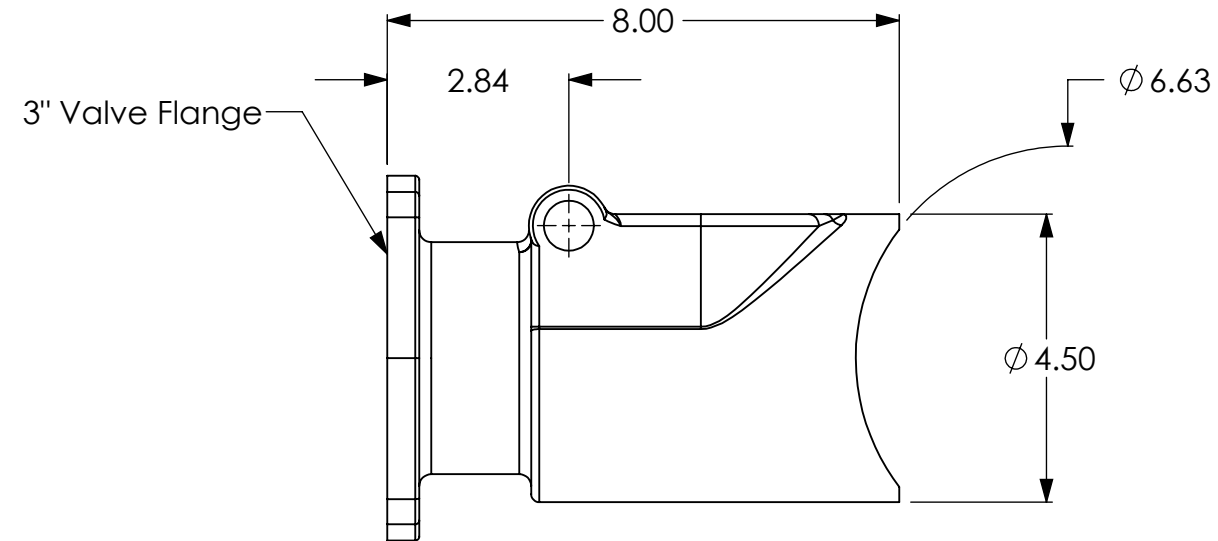

DRAWING NOTES UNLESS OTHERWISE SPECIFIED
 1. All dimensions are in inches.
 2. Do not scale drawing.
 3. Decimal Tolerance X.XX = +/- 0.01
 4. Decimal Tolerance X.XXX = +/- 0.005
 5. Fractional Tolerance X/X = +/- 1/16
 6. Angle Tolerance: 0.5 degrees

APPROXIMATE WEIGHT (LBS)
 10.02227029

THE INFORMATION CONTAINED IN THIS DRAWING IS THE SOLE PROPERTY OF FIRE PROGRAMS, LLC. ANY REPRODUCTION IN PART OR AS A WHOLE WITHOUT THE WRITTEN PERMISSION OF FIRE PROGRAMS, LLC IS PROHIBITED.

		6405 SW 38th St, Bldg 200 Ocala, FL 34474 Phone: 800.327.7638 www.fireprograms.com	
		TITLE Cstg 3.0 Vlv x W to 6.0 P w Check Vlv	
DRAWING NUMBER 500020		REV C	SHEET SCALE 1:3
		DATE 3/3/2021	SHEET 1 OF 1

REVISIONS		
REV.	DATE	DESCRIPTION
A	5/10/2010	Initial Release
B	7/10/2017	Add straight cut version 500020S.
C	3/3/2021	Removed straight cut version.